

Power units 45E and 40DT with double hydraulic pump

The power unit has two variable-flow hydraulic pumps, mounted in tandem. They are integrated in the hydraulic system in such way as to adjust their output to the power requirements of the drill unit in a most efficient way. Connections for an optional hydraulic driven flush pump are standard. Supplied complete with 70 litre oil tank, oil cooler and filters.

The electrical power unit 45E is powered by an asynchronous electric motor, and the diesel power unit 40DT with a Deutz turbo diesel, type BF4L 913.

	Power unit 45E	Power unit 40DT
Motor rating	45 kW (61 hp) at 1450 rpm	68 kW (92 hp) at 2200 rpm
Main pump		
flow	75 l/min (19.8 US gpm)	75 l/min (19.8 US gpm)
pressure	260 bar (3770 psi)	260 bar (3770 psi)
Service pump		
flow	29 l/min (7.4 US gpm)	44 l/min (11.5 US gpm)
pressure	210 bar (3045 psi)	210 bar (3045 psi)
Weights - Power units	615 kg (1353 lb)	810 kg (1782 lb)

Measurements in mm (in.)

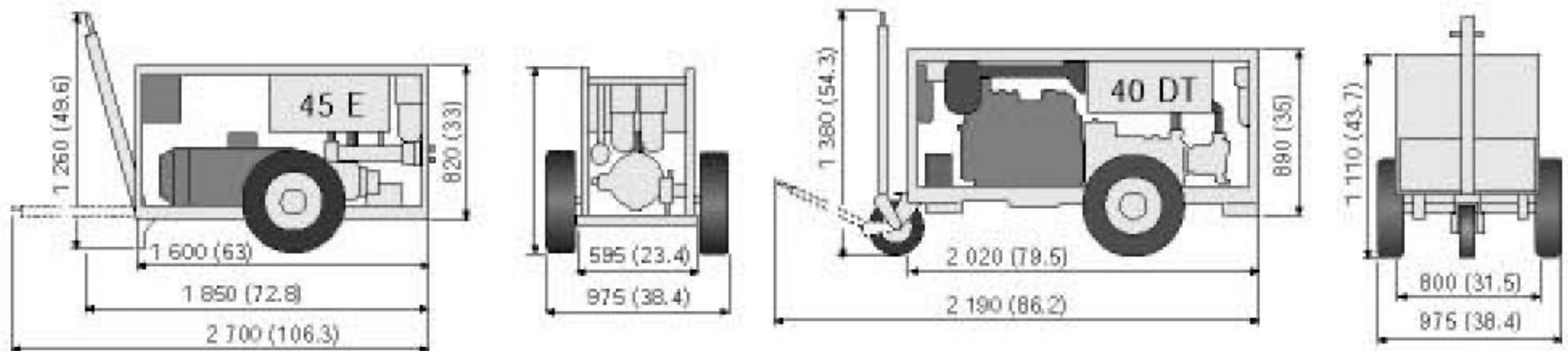

Weights in kg (lb) - Drill unit

Version	850	1800	3300
Drill unit**	1 040 kg (2 280 lb)	1 090 kg (2 400 lb)	1 170 kg (2 570 lb)
Control panel	170 kg (374 lb)	170 kg (374 lb)	170 kg (374 lb)

** Incl. Control panel

